

# Three-Leg VSC and a Transformer Based Three-Phase Four-Wire DSTATCOM for Distribution Systems

Bhim Singh, P. Jayaprakash\* and D. P. Kothari.

**Abstract-** A new three-phase four-wire DSTATCOM (distribution static compensator) based on three-leg VSC (voltage source converter) and a star/delta transformer is proposed for power quality improvement. The star/delta transformer connection mitigates the neutral current and the 3-leg VSC compensates harmonic current, reactive power and balances the load. Three single phase transformers are connected as star/delta transformer for interfacing to a three-phase four-wire power distribution system and the required rating of the VSC is reduced. The IGBT (insulated gate bipolar transistor) based VSC is capacitor supported and is controlled for the required compensation of the load current. The dc bus voltage of the VSC is regulated during varying load conditions. The performance of the three-phase four-wire DSTATCOM is validated for power factor correction and voltage regulation along with neutral current compensation, harmonic elimination and balancing of linear loads as well as non-linear loads using MATLAB software with its simulink and power system blockset (PSB) tool boxes.

**Keywords-** Power Quality Improvement, DSTATCOM, H-Bridge VSC, Voltage Source Converter, Star/delta Transformer, Neutral Current Compensation

## I. INTRODUCTION

THREE-PHASE four-wire distribution systems are facing severe power quality problems such as poor voltage regulation, high reactive power and harmonics current burden, load unbalancing, excessive neutral current etc. [1-6]. Three -phase four-wire distribution systems are used in commercial buildings, office buildings, hospitals etc. Most of the loads in these locations are non-linear loads and are mostly unbalanced load in the distribution system. This creates excessive neutral current both of fundamental and harmonic frequency and the neutral conductor gets overloaded. The voltage regulation is also poor in the distribution system due to the unplanned expansion and the installation of different types of loads in the existing distribution system. In order to control the power quality

problems, many standards are proposed such as IEEER-519 standard [1].

There are mitigation techniques for power quality problems in the distribution system and the group of devices is known by the generic name of custom power devices (CPD) [1]. The DSTATCOM (distribution static compensator) is a shunt connected CPD capable of compensating power quality problems in the load current. Some of the topologies of DSTATCOM for three-phase four-wire system for the mitigation of neutral current along with power quality compensation in the supply current are four-leg VSC (voltage source converter), three single phase VSC, three-leg VSC with split capacitors [4], three-leg VSC with zig-zag transformer [7-8], three-leg VSC with neutral terminal at the positive or negative of dc bus [9]. A set of three single phase VSC based DSTATCOM requires a total of twelve semiconductor devices and hence is not attractive and the three leg VSC with split capacitors has the disadvantage of difficulty in maintaining equal dc voltage at two series connected capacitors. A three- leg VSC with zig-zag transformer and a three-leg VSC with neutral terminal at the positive or negative of dc bus are reportedly recently and are having improved performance.

In this paper, a new topology of DSTATCOM is proposed for three-phase four-wire distribution system, which is based on 3-leg VSC and a star/delta transformer. The star/delta transformer is used in the three-phase distribution system very widely, but the application of star/delta transformer for circulating the neutral current near the load end along with a 3-leg VSC as DSTATCOM is discussed here. A star/delta transformer is proposed only for neutral current harmonics along with a single phase inverter [10-11]. The star/delta transformer mitigates the neutral current by providing a circulating path in the delta connected secondary winding. The required rating of star/delta transformer is calculated and the winding voltages are calculated for same current in all windings of the transformer. The voltage regulation in the distribution feeder is improved by installing a shunt compensator [12]. The proposed DSTATCOM is modelled and its performance is simulated and verified for power factor correction and voltage regulation along with neutral current compensation, harmonic elimination and load balancing with linear loads and non-linear loads.

Manuscript received July 15, 2008 and is revised on Sept 23, 2008.

Bhim Singh is with Dept. of Electrical Engg., Indian Institute of Technology, Delhi, Hauz-Khas, New Delhi-110016, India (e-mail: bsingh@ee.iitd.ac.in).

\*Corresponding author, P. Jayaprakash is with Centre for Energy Studies, Indian Institute of Technology, Delhi, Hauz-Khas, New Delhi-110016, India (Ph: 01126596225, 09911917411, e-mail: jayaprakashpee@gmail.com).

D. P. Kothari is with Vellore Institute of Technology, Vellore-632 014, Tamil Nadu, India. (e-mail: dpk0710@yahoo.com ).

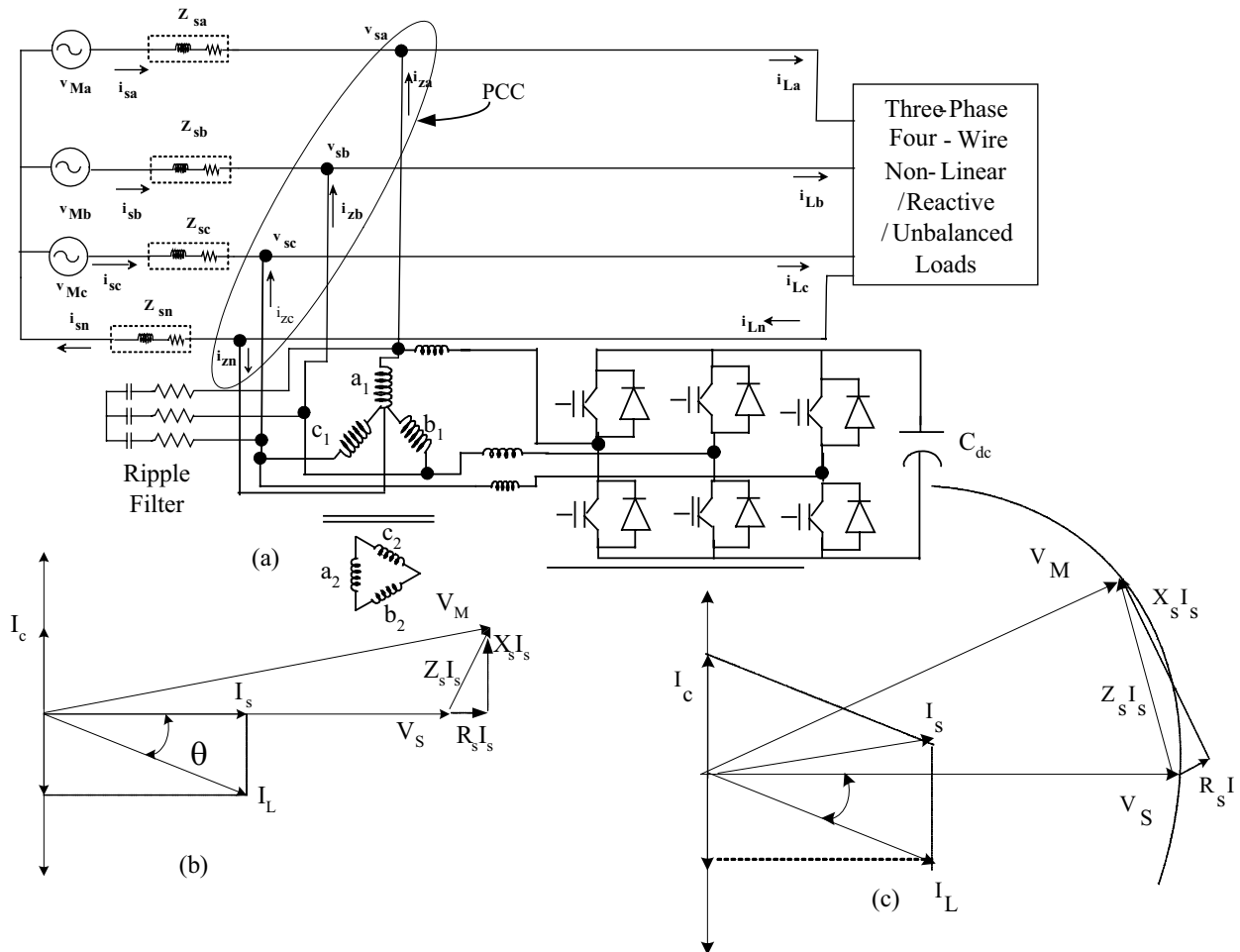

Fig. 1 Schematics of proposed 3-leg VSC with star/delta transformer based DSTATCOM in distribution system.

## II. PROPOSED DSTATCOM

Fig.1(a) shows the proposed DSTATCOM consisting of three-leg VSC and a star/delta transformer. The DSTATCOM can be operated for reactive power compensation in the mode of power factor correction or voltage regulation. Fig.1(b) shows the phasor diagram for the unity power factor operation. The DSTATCOM injects a current  $I_c$  such that the supply current is only  $I_s$  and this is inphase with voltage. The voltage regulation operation of DSTATCOM is depicted in the phasor diagram of Fig. 1(c). The DSTATCOM injects a current  $I_c$  such that the voltage at the load ( $V_s$ ) is equal to the source voltage ( $V_M$ ). The DC capacitor connected at the dc bus of the VSC acts as an energy buffer and establishes a dc voltage for the normal operation of the DSTATCOM system. The star/delta transformer is connected in shunt with the load and this is working as a neutral current compensator. A ripple filter is used at the point of common coupling (PCC) for reducing the high frequency ripple voltage in the voltage at PCC. The high frequency ripple voltage is due to the switching current of the VSC of the DSTATCOM.

## III. DESIGN AND CONTROL OF PROPOSED DSTATCOM

The proposed DSTATCOM topology has a VSC and a star/delta transformer. The VSC consists of six IGBTs (insulated gate bipolar transistors), three ac inductors and one dc capacitor. The required compensation to be provided by the DSTATCOM decides the rating of the VSC components. The data of considered DSTATCOM system for analysis is shown in Appendix. The VSC is designed for compensating a reactive power of 12 kVAR as decided from the load details. The selection of IGBTs, interfacing inductor, dc capacitor and the ripple filter are as per the design for a shunt dynamic compensator [13]. The dc bus voltage is calculated as 700V for a line voltage of 415V. The calculated value of  $C_{dc}$  is 2600  $\mu$ F and it is selected as 3000  $\mu$ F. The ac inductor,  $L_f$  of 2.5 mH is selected in this investigation.

### A. Design of star/delta Transformer

The selection of the star/delta transformer windings is based on the circulating current. The primary winding voltage is,

$$V_a = V_{LL} / (\sqrt{3}) = 415 / \sqrt{3} = 239.60V \quad (1)$$

Hence, a 240 V primary winding is selected in the star/delta transformer. The secondary line voltage is chosen for the same current to flow in the windings. The voltage ratio of the transformer is 1:1. Therefore, three numbers of single-phase transformers of each of rating 2.4 kVA, 240V/240V are selected. The voltages, currents and kVA rating of the star/delta transformer is given in Table I.

### B. Control of VSC of DSTATCOM

There are many control schemes reported in the literature for control of shunt active compensators such as instantaneous reactive power theory, power balance theory, synchronous reference frame theory, symmetrical components based etc. [14] and the synchronous reference frame theory is used for the control of proposed DSTATCOM. A block diagram of the control scheme is shown in Fig. 2. The load currents ( $i_{La}$ ,  $i_{Lb}$ ,  $i_{Lc}$ ), the PCC voltages ( $v_{sa}$ ,  $v_{sb}$ ,  $v_{sc}$ ) and dc bus voltage ( $v_{dc}$ ) of DSTATCOM are sensed as feedback signals. The load currents from the a-b-c frame are first converted to the  $\alpha$ - $\beta$ -o frame and then to the d-q-o frame as,

$$\begin{bmatrix} i_{Ld} \\ i_{Lq} \\ i_{Lo} \end{bmatrix} = \frac{2}{3} \begin{bmatrix} \cos \theta & -\sin \theta & \frac{1}{2} \\ \cos\left(\theta - \frac{2\pi}{3}\right) & -\sin\left(\theta - \frac{2\pi}{3}\right) & \frac{1}{2} \\ \cos\left(\theta + \frac{2\pi}{3}\right) & \sin\left(\theta + \frac{2\pi}{3}\right) & \frac{1}{2} \end{bmatrix} \begin{bmatrix} i_{La} \\ i_{Lb} \\ i_{Lc} \end{bmatrix} \quad (2)$$

where,  $\cos \theta$ ,  $\sin \theta$  are obtained using a three-phase PLL. The d-axis and q-axis currents consist of fundamental and harmonic components as,

$$i_{Ld} = i_{d dc} + i_{d ac} \quad (3)$$

$$i_{Lq} = i_{q dc} + i_{q ac} \quad (4)$$

#### 1) Unity power factor (UPF) operation of DSTATCOM

The compensating strategy for reactive power compensation for UPF operation considers that the source must deliver the mean value of the direct-axis component of

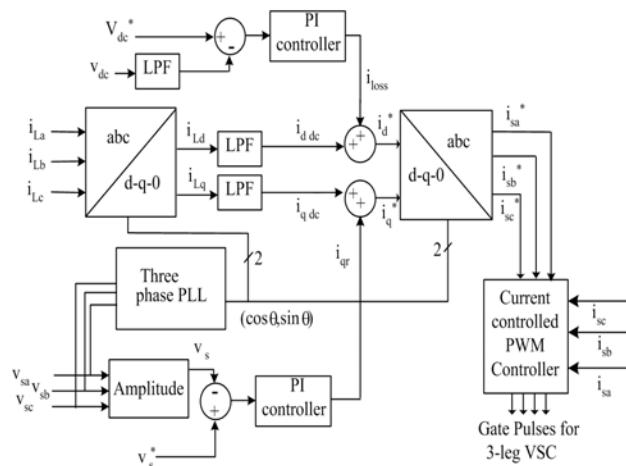

Fig. 2. Control algorithm for the three-leg VSC based DSTATCOM in a three phase four-wire system

the load current along with the active power component current for maintaining the dc bus and meeting the losses ( $i_{loss}$ ) in DSTATCOM. The output of PI (proportional-integral) controller at the dc bus voltage of DSTATCOM is considered as the current ( $i_{loss}$ ) for meeting its losses.

$$i_{loss(n)} = i_{loss(n-1)} + K_{pd}(v_{de(n)} - v_{de(n-1)}) + K_{id}v_{de(n)} \quad (5)$$

where,  $v_{de(n)} = v_{dc}^* - v_{dc(n)}$  is the error between the reference ( $v_{dc}^*$ ) and sensed ( $v_{dc}$ ) dc voltage at the  $n^{\text{th}}$  sampling instant.  $K_{pd}$  and  $K_{id}$  are the proportional and the integral gains of the dc bus voltage PI controller.

The reference source current is therefore as,

$$i_d^* = i_{d dc} + i_{loss} \quad (6)$$

The reference source current must be in phase with the voltage at the PCC but with no zero-sequence component. It is therefore obtained by the following reverse Park's transformation with the  $i_d^*$  as in (6) and  $i_q^*$  and  $i_o^*$  as zero.

#### 2) Zero voltage regulation (ZVR) operation of DSTATCOM

The compensating strategy for ZVR operation considers that the source must deliver the same direct axis component,  $i_d^*$  as mentioned in eqn. (6) along with the sum of quadrature axis current ( $i_{q dc}$ ) and the component obtained from the PI controller ( $i_{qr}$ ) used for regulating the voltage at PCC. The amplitude of ac terminal voltage ( $V_s$ ) at the PCC is controlled to its reference voltage ( $V_s^*$ ) using the PI controller. The output of PI controller is considered as the reactive component of current ( $i_{qr}$ ) for zero voltage regulation of ac voltage at PCC. The amplitude of AC voltage ( $V_s$ ) at PCC is calculated from the ac voltages ( $v_{sa}, v_{sb}, v_{sc}$ ) as,

$$V_s = (2/3)^{1/2} (v_{sa}^2 + v_{sb}^2 + v_{sc}^2)^{1/2} \quad (7)$$

Then, a PI controller is used to regulate this voltage to a reference value as,

$$i_{qr(n)} = i_{qr(n-1)} + K_{pq}(v_{te(n)} - v_{te(n-1)}) + K_{iq}v_{te(n)} \quad (8)$$

where,  $v_{te(n)} = V_s^* - V_{S(n)}$  denotes the error between reference ( $V_s^*$ ) and actual ( $V_{S(n)}$ ) terminal voltage

amplitudes at the  $n^{\text{th}}$  sampling instant.  $K_{pq}$  and  $K_{iq}$  are the proportional and the integral gains of the dc bus voltage PI controller. The reference supply quadrature axis current is as

$$i_q^* = i_{q dc} + i_{qr} \quad (9)$$

The reference source current is obtained by the following reverse Park's transformation with the  $i_d^*$  as in (6) and  $i_q^*$  as in (9) and  $i_o^*$  as zero.

#### 3) Current controlled PWM generator

In a current controller, the sensed and reference supply currents are compared and a proportional controller is used for amplifying current error in each phase before comparing with a triangular carrier signal to generate the gating signals for six IGBT switches of VSC of DSTATCOM.

## IV. MATLAB MODELLING OF DSTATCOM SYSTEM

The three-leg VSC and the star/delta transformer based DSTATCOM connected to a three-phase four-wire system is

modeled and simulated using the MATLAB with its Simulink and Power System Blockset toolboxes. The system data are given in Appendix. The MATLAB based model of the three-phase four-wire DSTATCOM shown in Fig. 1(a) is developed. The ripple filter is connected to the DSTATCOM for filtering the ripple in the PCC voltage.

The control algorithm for the DSTATCOM is also modelled in MATLAB. The reference source currents are derived from the sensed PCC voltages ( $v_{sa}$ ,  $v_{sb}$ ,  $v_{sc}$ ), load currents ( $i_{La}$ ,  $i_{Lb}$ ,  $i_{Lc}$ ) and the dc bus voltage of DSTATCOM ( $v_{dc}$ ). A pulse width modulated (PWM) current controller is used over the reference and sensed source currents to generate the gating signals for the IGBTs of the VSC of the DSTATCOM.

## V. RESULTS AND DISCUSSION

The performance of the star/delta transformer and 3-leg VSC based three-phase four-wire DSTATCOM is demonstrated for power factor correction and voltage regulation along with harmonic reduction, load balancing and neutral current compensation. The developed model is analysed under varying loads and the results are discussed below.

### A. Performance of DSTATCOM with linear load for neutral current compensation, load balancing and ZVR Operation

The dynamic performance of the DSTATCOM under linear lagging power factor unbalanced load condition is shown in Fig. 3. At 0.6 sec, the load is changed to two-phase load and again to single-phase load at 0.7 sec. These loads are applied again at 0.8 sec and 0.9 sec respectively. The PCC voltages ( $v_s$ ), supply currents ( $i_s$ ), load currents ( $i_L$ ), compensator currents ( $i_c$ ), supply neutral current ( $i_{Sn}$ ), load neutral current ( $i_{Ln}$ ), compensator neutral current ( $i_{Tn}$ ), dc bus voltage ( $v_{dc}$ ), amplitude of voltage ( $V_s$ ) at PCC and the kVA rating of star/delta transformer are also depicted in Fig. 3. The supply neutral current is observed as nearly zero and this verifies the proper compensation. It is also observed that the dc bus voltage of DSTATCOM is able to maintain close to the reference value under all disturbances. The amplitude of PCC voltage is maintained at the reference value under various load disturbance which shows the ZVR mode of operation of DSTATCOM.

### B. Performance of DSTATCOM with non-linear load for neutral current compensation, load balancing and ZVR operation

The dynamic performance of the DSTATCOM with non-linear and unbalanced load is given in Fig. 4. The PCC voltages ( $v_s$ ), supply currents ( $i_s$ ), load currents ( $i_{La}$ ,  $i_{Lb}$ ,  $i_{Lc}$ ), compensator currents ( $i_c$ ), supply neutral current ( $i_{Sn}$ ), compensator neutral current ( $i_{Tn}$ ), load neutral current ( $i_{Ln}$ ), dc bus voltage ( $v_{dc}$ ) and amplitude of voltage ( $V_s$ ) at PCC and the kVA rating of star/delta transformer are demonstrated. It is observed that the harmonic current is compensated and the supply currents are balanced and

sinusoidal. At 0.8 sec, the load is changed to two-phase load and again to single-phase load at 0.9 sec. The loads are applied again at 1.0 sec and 1.1 sec respectively. The supply currents are still balanced and sinusoidal even when the load current in a phase is zero.

### C. Performance of DSTATCOM with linear load and non-linear load for neutral current compensation, load balancing and UPF Operation

The dynamic performance of the DSTATCOM during linear and non-linear, balanced/unbalanced load condition is shown in Figs. 5 and 6 respectively. The supply currents are observed as balanced and sinusoidal under all these conditions. At 0.8 sec, the load is changed to two-phase load and again to single-phase load at 0.9 sec. The loads are applied again at 1.0 sec and 1.1 sec respectively. The PCC voltages ( $v_s$ ), supply currents ( $i_s$ ), load currents ( $i_{La}$ ,  $i_{Lb}$ ,  $i_{Lc}$ ), compensator currents ( $i_c$ ), supply neutral current ( $i_{Sn}$ ), compensator neutral current ( $i_{Tn}$ ), load neutral current ( $i_{Ln}$ ), dc bus voltage ( $v_{dc}$ ) and amplitude of voltage ( $V_s$ ) at PCC and the kVA rating of star/delta transformer are demonstrated. The dc bus voltage of DSTATCOM is maintained at the reference value under all load disturbances through proper control. The amplitude of PCC voltage is not regulated to the reference value under load disturbances. The waveform of the load current, supply current and PCC

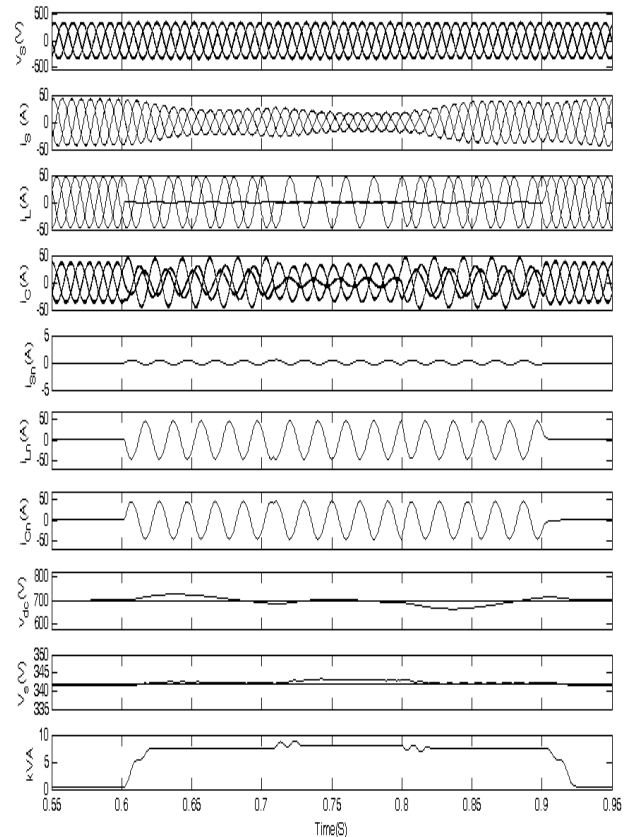

Fig. 3. Performance of 3-phase Three-leg VSC and star/delta transformer based DSTATCOM for neutral current compensation, load balancing and voltage regulation.

voltage in one phase along with their harmonic spectra are demonstrated in Fig. 7, Fig. 8 and Fig. 9 respectively. The total harmonic distortion (THD) of the supply current is 1.72%, where as that of the load current is 63.50% and this shows the satisfactory performance of DSTATCOM for harmonic compensation as stipulated by IEEE-519 standard.

### VI. CONCLUSION

The performance of a new topology of three-phase four-wire DSTATCOM consisting of three-leg VSC with a star/delta transformer has been demonstrated for neutral current compensation along with reactive power compensation, harmonic elimination and load balancing. The voltage regulation and power factor correction modes of operation of the DSTATCOM have been observed as expected ones. The dc bus voltage of the DSTATCOM has been regulated to the reference dc bus voltage under varying loads. The star/delta transformer has been found effective for compensating the zero sequence fundamental and harmonics currents and the kVA rating of the star/delta transformer has been verified by simulation. It is observed that the kVA rating of the transformer is about 40% of the load kVA and the reactive power to be compensated.

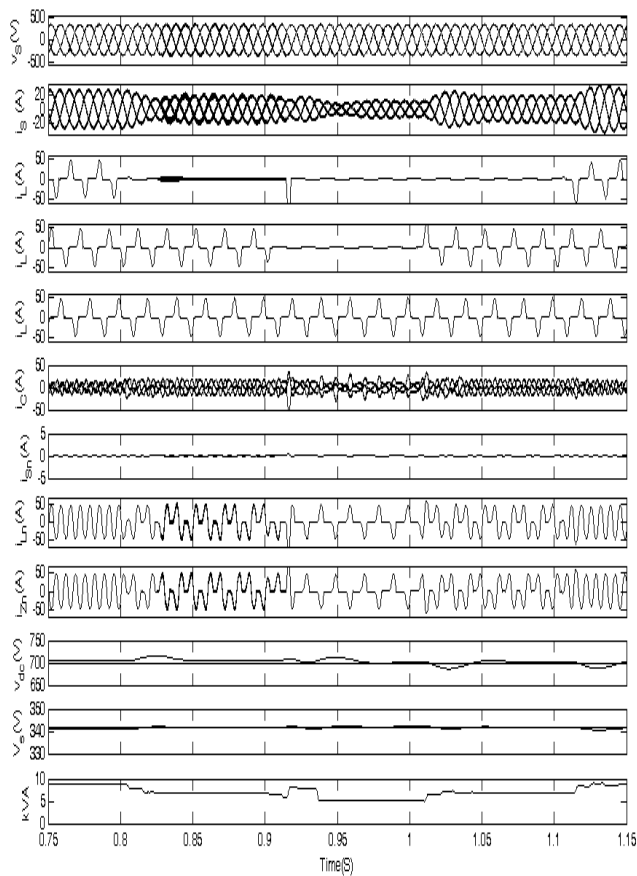

Fig. 4. Performance of 3-phase Three-leg VSC and star/delta transformer based DSTATCOM for neutral current compensation, load balancing, harmonic compensation and voltage regulation.

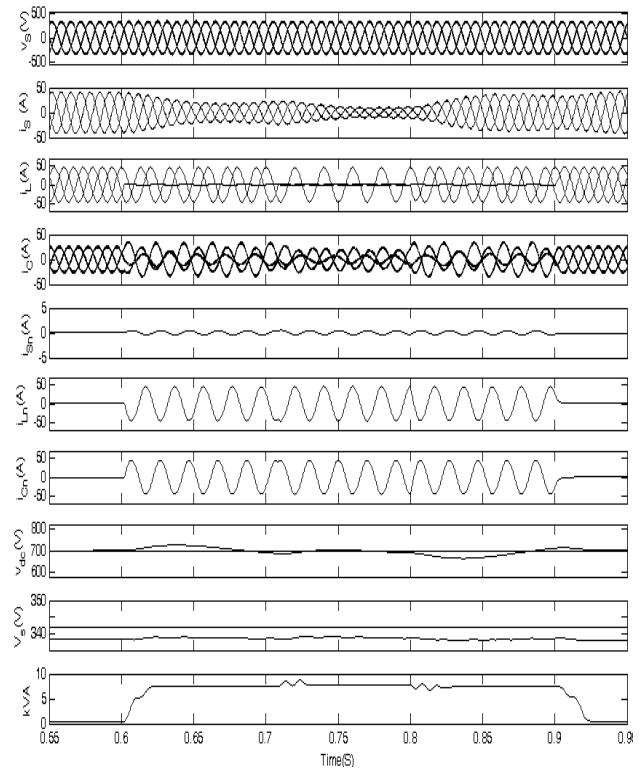

Fig. 5. Performance of 3-phase Three-leg VSC and star/delta transformer based DSTATCOM for neutral current compensation, load balancing and power factor correction.

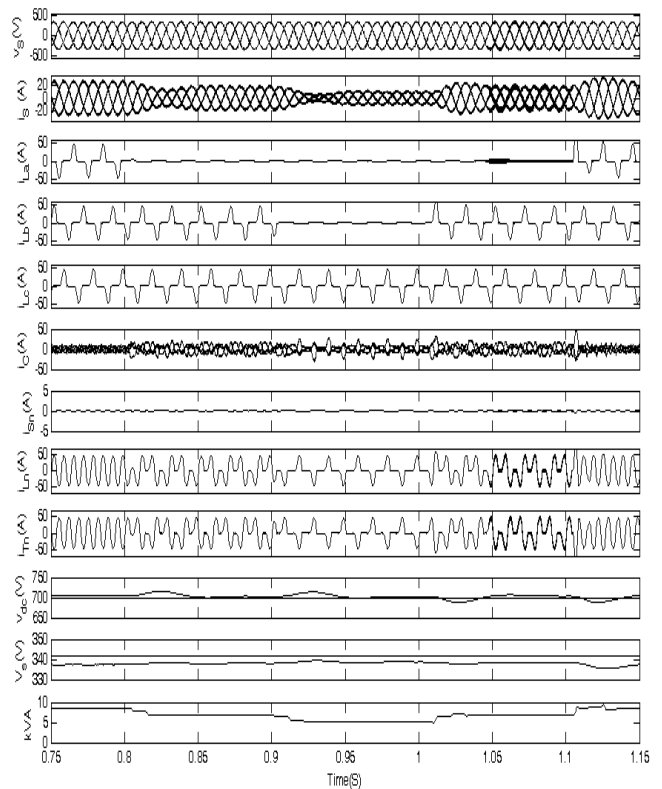

Fig. 6. Performance of 3-phase Three-leg VSC and star/delta transformer based DSTATCOM for neutral current compensation, load balancing, harmonic compensation and power factor correction

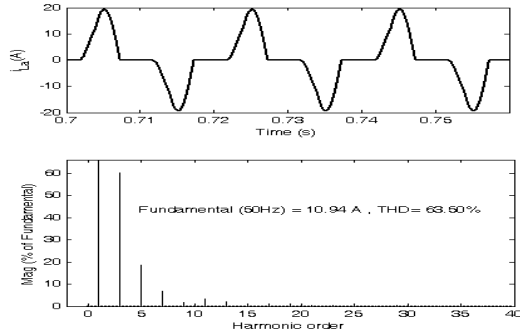

Fig. 7 Load current and the harmonic spectrum

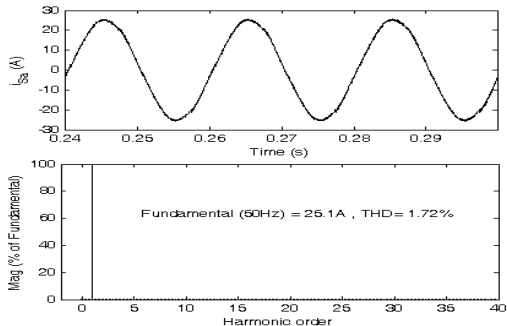

Fig. 8 Source current and the harmonic spectrum

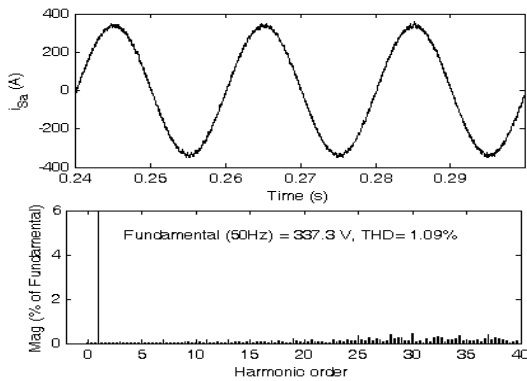

Fig. 9 Voltage at PCC and the harmonic spectrum

## APPENDIX

Line Impedance:  $R_s=0.01 \Omega$ ,  $L_s= 2 \text{ mH}$   
 Loads: (i) Linear: 20 kVA, 0.80 pf lag  
 (ii) Non-linear: Three single-phase bridge rectifiers with  $R = 25 \Omega$  and  $C = 470\mu\text{F}$   
 Ripple filter:  $R_f= 5 \Omega$ ,  $C_f= 5 \mu\text{F}$   
 DSTATCOM:  
 DC bus voltage of DSTATCOM: 700 V  
 DC bus capacitance of DSTATCOM: 3000  $\mu\text{F}$   
 AC inductor: 2.5 mH  
 DC voltage PI controller:  $K_{pd}=0.19$ ,  $K_{id}=6.25$   
 PCC voltage PI controller:  $K_{pq}=0.9$ ,  $K_{iq}=7.5$   
 AC line voltage: 415 V, 50 Hz  
 PWM switching frequency: 10 kHz  
 Star/Delta Transformer: Three single-phase transformers of rating 2.4kVA, 240V/240V.

 TABLE I.  
 RATING OF TRANSFORMER FOR NEUTRAL CURRENT COMPENSATION

Transformer	winding Voltage (V)	winding Current (A)	kVA	Nos	Total kVA
Star/Delta	240/240	10	2.4	3	7.2

## REFERENCES

- [1] *IEEE Recommended Practices and Requirements for Harmonics Control in Electric Power Systems*, IEEE Std. 519, 1992.
- [2] A.Ghosh and G. Ledwich, *Power Quality Enhancement using Custom Power Devices*, Kluwer Academic Publishers, London, 2002.
- [3] R. C. Dugan, M. F. McGranaghan and H. W. Beaty, *Electric Power Systems Quality*. 2<sup>nd</sup> Edition, McGraw Hill, New York, 2006.
- [4] H. Akagi, E H Watanabe and M Aredes, *Instantaneous power theory and applications to power conditioning*, John Wiley & Sons, New Jersey, USA, 2007.
- [5] Antonio Moreno-Munoz, *Power Quality: Mitigation Technologies in a Distributed Environment*, Springer-Verlag London limited, London, 2007.
- [6] Ewald F. Fuchs and Mohammad A. S. Mausoum, *Power Quality in Power Systems and Electrical Machines*, Elsevier Academic Press, London, UK, 2008.
- [7] Hung- Liahng Jou, Jinn- Chang Wu, Kuen- Der Wu, Wen- Jung Chiang and Yi- Hsun Chen, "Analysis of zig-zag Transformer applying in the three-phase Four- Wire Distribution Power System," *IEEE Trans. Power Delivery*, vol. 20, no. 2, pp. 1168- 1173, April 2005.
- [8] Hung-Liahng, Kuen- Der Wu, Jinn- Chang Wu and Wen- Jung Chiang, "A three-phase four- wire power filter comprising a three-phase three-wire active filter and a zig-zag transformer," *IEEE Trans. of Power Electronics.*, vol. 23, No. 1, pp. 252- 259, Jan. 2008.
- [9] H.L.Jou, K. D. Wu, J. C. Wu, C. H. Li and M. S. Huang, "Novel power converter topology for three-phase four-wire hybrid power filter", *IET Power Electron.*, vol.1, No.1, pp. 164-173, 2008.
- [10] Sikyung Kim, Prasad N. Enjeti and Ira J. Pitel, "A New approach to improve power factor and reduce harmonics in a three-phase diode rectifier type utility interface," *IEEE Trans. Ind. Applicat.*, vol. 30, no. 6, pp. 1557- 1564, Nov./ Dec 1994.
- [11] P. Vedelho and G D Marques, "A neutral current electronic compensator," in *Proc. of IEEE Proceedings in Industrial Electronics*, vol.2, pp.831-836, Aug/Sept 1998.
- [12] H. Fugita and H. Akagi, "Voltage-regulation performance of a shunt active filter intended for installation on a power distribution system," *IEEE Trans. on Power Electron.*, vol. 22, no.1, pp. 1046-1053, May 2007.
- [13] B.N.Singh, P.Rastgoufard, B.Singh, A.Chandra and K.Al.Haddad, "Design, simulation and implementation of three pole/ four pole topologies for active filters," *IEE Electr. Power Appl.*, vol. 151, no. 4, pp. 467-476, July 2004.
- [14] Maria Isabel Milanés, Enrique Romero Cadaval and Fermín Barrero González, "Comparison of Control Strategies for Shunt Active Power Filters in Three-Phase Four-Wire Systems," *IEEE Trans. on Power Electron.*, vol. 22, no. 1, pp.229-236, Jan. 2007.