

Output variables

$v_a=nodev_of_a$
 $v_b=nodev_of_b$
 $i_R=i1_of_R$

Solve sections

transient simulation
 back_euler=yes

$t_start=0$
 $t_end=10m$
 $delt_const=0.05m$

output block:

filename=rc1.dat
 variables: v_a v_b i_R

1. Plot v_a and v_b (versus time) on the same plot.
2. Plot i_R in a separate plot.
3. Plot v_a , v_b , i_R on the same plot.
4. Change R to 0.1 K, and see its effect on the results.

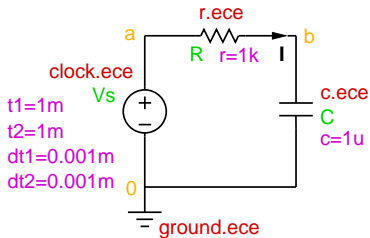

$t1=1m$
 $t2=1m$
 $dt1=0.001m$
 $dt2=0.001m$

Output variables

$v_a=nodev_of_a$
 $v_b=nodev_of_b$
 $i_R=i1_of_R$

Solve sections

transient simulation
 back_euler=yes

$t_start=0$

$t_end=10m$

$delt_const=0.001m$

output block:

filename=rc1.dat

variables: v_a v_b i_R

1. Plot v_a and v_b (versus time) on the same plot.
2. Plot i_R in a separate plot.
3. Plot v_a , v_b , i_R on the same plot.
4. Change R to 0.1 K, and see its effect on the results.

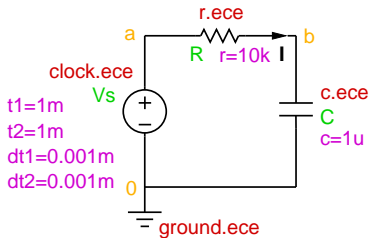

Output variables

v_a=nodev_of_a
v_b=nodev_of_b
i_R=i1_of_R

Solve sections

SSW analysis
back_euler=yes
t_start=0

ssw_period=2m
delt_const=0.001m

output block:

filename=rc1.dat
variables: v_a v_b i_R

1. Plot v_a and v_b (versus time) on the same plot.
2. Plot i_R in a separate plot.
3. Derive a general expression for the lower and upper limits between which v_b varies in the steady state.

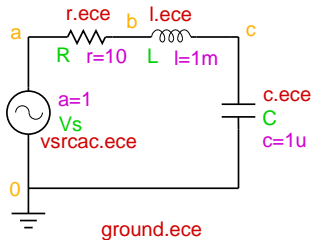

Output variables

`i_R_ac=i1ac_of_R`

1. Plot $|j|$ as a function of frequency (semi-log).
2. Plot $\text{angle}(i)$ as a function of frequency (semi-log).
3. Decrease R by a factor of 2 and repeat.
(Plot the two cases together.)

Solve sections

AC simulation

`vary_frequency`

`100 to 100k`

`type=log`

`n_points=500`

output block:

`filename=rlc1.dat`

variables:

`phase_of_i_R_ac`

`mag_of_i_R_ac`

SEQUEL exercise

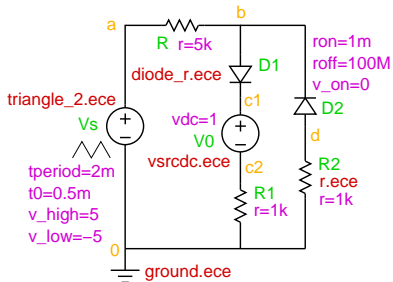

Output variables

v_a=nodev_of_a
v_b=nodev_of_b
i_D1=i1_of_D1
i_D2=i1_of_D2

Solve sections

transient simulation

back_euler=yes

t_start=0

t_end=2m

delt_const=1u

output block:

variables: v_a v_b i_D1 i_D2

1. Plot v_a and v_b versus time.
2. Plot v_b versus v_a . Explain the plot.
3. Plot i_{D1} and i_{D2} versus v_a .
4. Change v_{on} from 0 to 0.7 and repeat.
5. Replace diode_r.ece with diode_spice_1.ece and repeat.

SEQUEL exercise

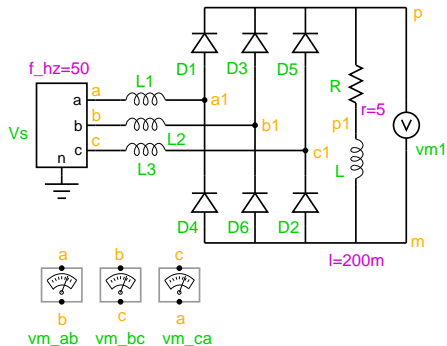

Output variables

$i_{D1}=i1_of_D1$
 $v_{ab}=v1_of_vm_{ab}$
 $i_{L1}=i1_of_L1$
 $v_{out}=v1_of_vm1$
 (etc)

Solve sections

SSW analysis

back_euler=yes

t_start=0

ssw_period=20m

delt_const=0.02m

output block 1

variables: v_out v_ab

chk_rhs2=no

chk_delx_volt=yes

delx_max_volt=0.1

ssw_norm=1e-12

Elements

vsrca3.ece

l.ece, r.ece

diode_r.ece

voltmeter.ece

vdiff.ece

Global parameters

1. For V_s , $v_a=v_b=v_c=v_0=560$

2. For diodes, $r_{on}=r_{off}=0.1m$

3. For diodes, $r_{off}=r_{on}=1M$

4. For diodes, $v_{on}=v_{off}=0$

5. $L_1=L_2=L_3=L_0=1u$

1. Plot v_{out} and v_{ab} versus time.

2. Plot i_{D1} versus time.

3. Make $L_0=0.5m$ and repeat.

SEQUEL exercise

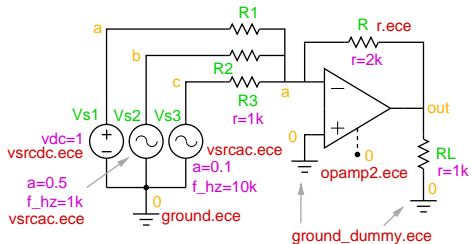

Output variables

$v_a=nodev_of_a$
 $v_b=nodev_of_b$
 $v_c=nodev_of_c$
 $v_o=nodev_of_out$

Solve sections

transient simulation
back_euler=yes
 $t_start=0$
 $t_end=5m$
 $delt_const=1u$
output block:
variables: v_a v_b v_c v_o

1. Note the use of ground_dummy.ece.
2. opamp2.ece is a linear Op Amp model.
3. Plot v_a , v_b , v_c , v_o versus time