

ee101_inv_amp_2.sqproj

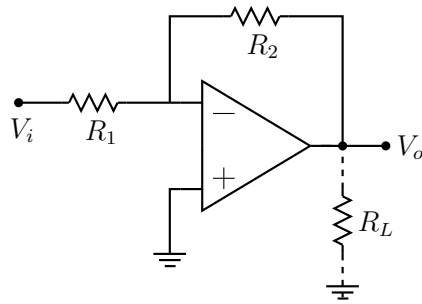

Shown in the figure is an inverting amplifier for which

$$V_o = -\frac{R_2}{R_1} V_i. \quad (1)$$

The above relationship is valid if the Op Amp operates in the linear regime (i.e., $-V_{\text{sat}} < V_o < V_{\text{sat}}$). Another condition for Eq. 1 to be valid has to do with the “slew rate” of the Op Amp, i.e., the maximum rate at which the Op Amp output can change. An ideal Op Amp would be able to follow arbitrarily fast changes in the input voltages, i.e., its slew rate would be ∞ . For a real Op Amp, the slew rate is finite. For example, the slew rate for the 741 Op Amp is $0.5 \text{ V}/\mu\text{sec}$, which means that the output can change by not more than 0.5 V in one microsecond.

Exercise Set

1. For a sinusoidal input voltage with amplitude 1 V and frequency 25 kHz , simulate the inverting amplifier with $R_1 = 1 \text{ k}\Omega$, $R_2 = 10 \text{ k}\Omega$, and an Op Amp 741 model. You will observe that the output is slew rate limited. From this plot, estimate the slew rate of the Op Amp.
2. Decrease the frequency of the input voltage until the output *just* becomes distortion-free. How is this frequency related to the slew rate of the Op Amp? (Hint: Think of the maximum rate of change of the input voltage.)