

ee101_network_7.sqproj

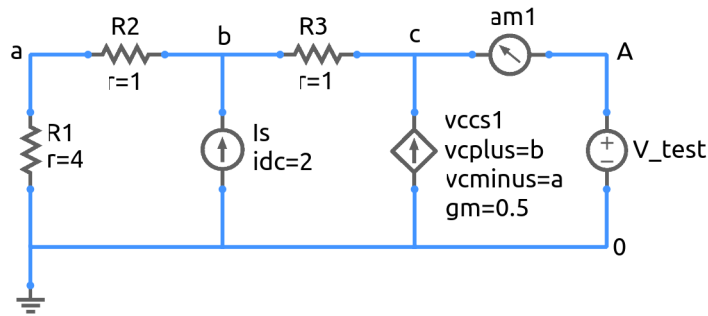

Description

In the circuit shown in the figure, the current through the VCCS is given by $g_m (V_b - V_a)$. We are interested in finding the Thevenin equivalent circuit as seen from the port A-0.

Exercise Set

1. Find the Thevenin voltage $V_{Th} = V_{OC}$ (on paper).
2. Find the Thevenin resistance R_{Th} (on paper) by deactivating the independent source (I_S), applying a test voltage source (voltage V_{test}) between A and 0, and finding the current (I_{test}) through the test source. R_{Th} is then given by $R_{Th} = V_{test}/I_{test}$.
3. To check your V_{Th} and R_{Th} values, run the simulation, and plot the current through the ammeter versus V_{test} . The y -intercept gives the short-circuit current I_{SC} , the x -intercept gives the open-circuit voltage V_{OC} (which is the same as V_{Th}), and R_{Th} is then given by $R_{Th} = V_{OC}/I_{SC}$.